



SOLID
TO SUCCEED

ARTICULATED BOOM LIFT

XGA12ACK



The print does not belong to the contract, nor a part of the vehicle purchase contract. We reserve the right to revise the product model, parameters, configuration based on the continuous improvement requirements of the product, without prior notice. Pictures are for reference only, and the specific product shall depend on the real product.

XGA12ACK

Articulated Boom Lift

FEATURES

MEASUREMENTS

11.56m working height
Up to 230kg lift capacity

PRODUCTIVITY

1.17m×0.76m steel platform
230kg platform load capacity
160° platform rotation
2-wheel drive
2-wheel braking system
35% theoretical gradeability
Horn
Tilt alarm
Thumb rocker steering
Positive defense system
Proportional handle control
Lowering and motion alarm
Automatic leveling of platform
Platform automatic leveling system
Platform and ground emergency stop button

POWER

400Ah/48V Lead-acid batteries
1.9kW/12V DC emergency control unit
12V DC proportional control

OPTIONS

Tool tray
Air line to platform
Platform working light
Solid non-marking tires
AC power cords to platform

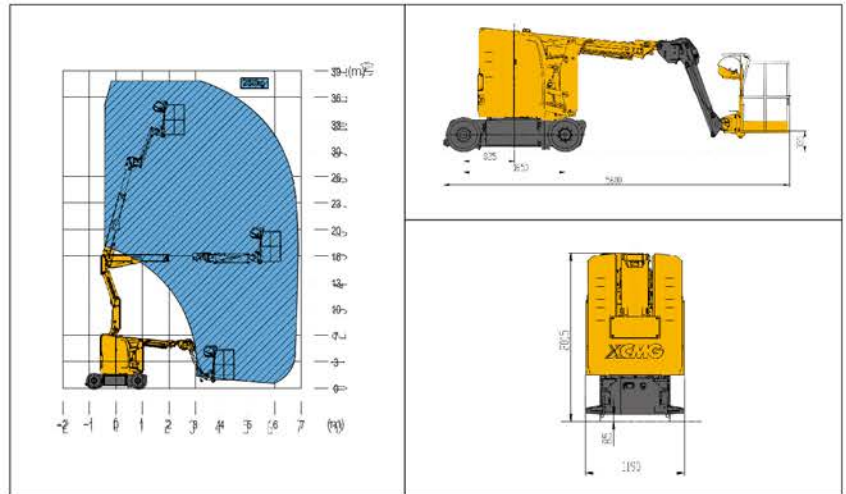

Item	Unit	XGA12ACK
Working height	m	11.56
Platform height	m	9.56
Working radius	m	6.87
Lift capacity	kg	230
Occupant capacity	-	2
1st Boom luffing range	°	-12.5~+70
2nd Boom luffing range	°	-5.5~+75
Fly jib luffing range	°	-70~+70
Turntable rotation	°	355
Platform rotation	°	160
Drive speed (retracted/extended)	km/h	5/0.6
Turning radius(inside/outside)	m	1.76/3.25
Tailswing	mm	0
Ground clearance	mm	85
Gradeability	%	35
Tires	—	22×7
Control system	—	12V DC proportional control
Emergency control unit	kW/V	1.9/12
Batteries	V/Ah	48/400
Charger	V/A	48/35
Main power unit	kW/V	4.5/32
Drive motor	kW/V	3.3/32
Hydraulic tank	L	13
Weight	kg	7000
Platform size	mm	1170×760×1150
a Length (transportation)	mm	5600(5360)
b Width	mm	1190
c Height	mm	2015
d Wheelbase	mm	1650